

Construction in Flood Hazard Areas

October 2014

Presented By
Douglas M. Schanne
Training Program Supervisor
Office of Education and Data Management
Division of Construction Services
State of Connecticut

2014 NEW ENGLAND BUILDING OFFICIALS EDUCATION ASSOCIATION CONFERENCE



Construction in Flood Hazard Areas





This class will review the Flood Resistant Construction requirements of the State Building Code and provisions of both the IRC and IBC.

- General requirements, alternate provisions, structural systems, design flood elevations, lowest floor requirements, protection of mechanical and electrical systems and the protection of water supply and sanitary sewage systems will also be discussed.

Objectives

- Program will provide an overview of code requirements for construction in the Flood Hazard Areas.
- Discuss Flood Construction Requirements from the 2003/2012 IBC and the 2009/2012 IRC.
- Will review code sections and reference some of the federal guidelines for construction in flood hazard area.


History of Flooding in Connecticut

Reproduction information available from the Connecticut State Library, State Archives
File name: 35flood16

Ansonia, October 16, 1955
Ansonia, New York, New Haven and Hartford Railroad, October 16, 1955
U. S. Coast Guard

History of Flooding in Connecticut



Reproduction information available from the Connecticut State Library, State Archives
File name: 35flood16

Naugatuck, August 19, 1955

History of Flooding in Connecticut



Reproduction information available from the
Connecticut State Library, State Archives
File name: 35800d29
Putnam, August 19, 1955, *The Louis S. Edman Collection*

History of Flooding in Connecticut



Waterbury, August 1955. Water pours from the windows of the American Brass ...



Irene – Flooding along the Farmington River



Tunxis Plantation Golf Course in Farmington is underwater after the Farmington River overflowed its bank after Tropical Storm Irene



Houses and cottages along the Old Saybrook shore after Tropical Storm Irene



Cottages along the shore in East Haven were severely damaged by Tropical Storm Irene

Building Code

- International Building Code
 Flood Hazard Areas Requirements Overview
- Chapter 1 – Administration
 - Chapter 2 – Definitions
 - Chapter 11 – Accessibility
 - Chapter 14 – Exterior Walls
 - Chapter 16 – Structural Design
 - Reference to Definitions
 - Chapter 18 - Soils and Foundations

IBC Chapter 1 - Administration

101.2 Scope. *(Note: language modifications and amendments CT, 03 & 12)*
 The provisions of this code shall apply to the construction, alteration, *relocation*, enlargement, replacement, repair, equipment, use and occupancy, location, maintenance, removal and demolition of every building or structure or any appurtenances connected or attached to such buildings or structures.
 Exceptions:
 1. Detached one- and two-family dwellings and multiple single-family dwellings (town houses) not more than three stories above grade plane in height with a separate means of egress and their accessory structures shall comply with the *International Residential Code*.
 2. Existing buildings undergoing repair, alterations or additions and change of occupancy shall be permitted to comply with the *International Existing Building Code*.

IBC Chapter 1 - Administration

- 104.10.1 Flood hazard areas *(Note: language modifications from 2012 IBC)*
- In the IBC Model Code, This section adds limitation that the building official shall not grant modifications to any provision required in the flood hazard areas as established by Section 1612.2 unless a specific determination has been made (equivalent to variance provisions).
 - *In Connecticut only the State Building Inspector can grant modifications to the building code.*

IBC Chapter 1 - Administration

106.2 Site plan. (2003) and 107.2.5 Site plan. (2012)
 The construction documents submitted with the application for permit shall be accompanied by a site plan showing to scale the size and location of new construction and existing structures on the site, distances from lot lines, the established street grades and the proposed finished grades and, as applicable, flood hazard areas, floodways, and design flood elevations; and it shall be drawn in accordance with an accurate boundary line survey. In the case of demolition, the site plan shall show construction to be demolished and the location and size of existing structures and construction that are to remain on the site or plot. The building official is authorized to waive or modify the requirement for a site plan when the application for permit is for alteration or repair or when otherwise warranted.

IBC Administration

109.3.3 Lowest floor elevation. (2003)
 110.3.3 *Lowest floor elevation. (2012)*
 In flood hazard areas, upon placement of the lowest floor, including the basement, and prior to further vertical construction, the elevation certification required in Section 1612.5 shall be submitted to the building official.

IBC

IBC CHAPTER 2 - Definitions
 Section 202 – Definitions

- Flood Related Definitions are listed in the 2012 IBC and are referenced in Section 1612.2
- Flood Related Definitions in the 2003 IBC reference Section 1612.2

IBC CHAPTER 8 - INTERIOR FINISHES
 Section 801.5 was added for the IBC 2009 edition and modified for the IBC 2012 edition using elevation required by Section 1612.
 801.5 Applicability. For buildings in flood hazard areas as established in Section 1612.3, interior finishes, trim and decorative materials below the elevation required by section 1612 shall be flood-damage-resistant materials.

IBC Chapter 11 – Accessibility

Section 1107.7 General Exceptions

1107.7.5 Design flood elevation.

The required number of Type A and Type B units shall not apply to a site where the lowest floor or the lowest structural building members of nonelevator buildings are required to be at or above the design flood elevation resulting in:

1. A difference in elevation between the minimum required floor elevation at the primary entrances and vehicular and pedestrian arrival points within 50 feet (15 240 mm) exceeding 30 inches (762 mm), and
2. A slope exceeding 10 percent between the minimum required floor elevation at the primary entrances and vehicular and pedestrian arrival points within 50 feet (15 240 mm).

Where no such arrival points are within 50 feet (15 240 mm) of the primary entrances, the closest arrival point shall be used.

IBC Chapter 14 – Exterior Walls

Section 1403 – Performance Requirements

- Section 1403.6 Flood Resistance
 - Exterior Walls extending below the *design flood elevation** shall be resistant to water damage
 - * 2012 replaces the design flood elevation (DFE) with lowest floor elevation specified in Section 1612.
- Section 1403.7 Flood Resistance for High-Velocity Wave Action Areas
 - Electrical, Mechanical and Plumbing System Components shall not be mounted on or penetrate through exterior walls designed to break away under flood loads

IBC Chapter 16 Structural Design

- Section 1612 – Flood Loads
- General
- Definitions
- Establishment of Flood Hazard Areas
- Design and Construction
- Flood Hazard Documentations

Section 1612 - Flood Loads

1612.1 General.

Within flood hazard areas as established in Section 1612.3,

- All new construction of buildings, structures and portions of buildings and structures,
- Including substantial improvements and restoration of substantial damage to buildings and structures,
- Shall be designed and constructed to resist the effects of flood hazards and flood loads.
- *For buildings that are located in more than one flood hazard area, the provisions associated with the most restrictive flood hazard area shall apply.*

Section 1612.2 Definitions

- Base Flood
- Base Flood Elevation
- Design Flood
- Design Flood Elevation
- Flood or Flooding
- Flood Hazard Area
- Flood Hazard Area Subject to High Velocity Wave Action
- Special Flood Hazard Area
- Substantial Damage
- Substantial Improvement

Flood or Flooding

- Flood or Flooding

A general and temporary condition of partial or complete inundation of normally dry land from:

 1. The overflow of inland or tidal waters
 2. The unusual and rapid accumulation or runoff of surface waters from any source

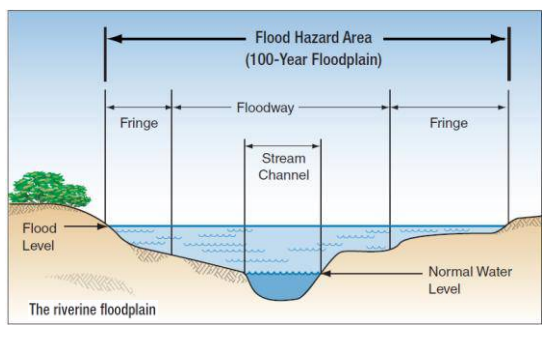
Design Flood

- Design Flood
 - The Flood associated with the greater of the following two areas:
 - 1. Area with a flood plain subject to a 1-percent or greater chance of flooding in any year;
 - 2. Area designated as a flood hazard area on a **community's flood hazard map, or otherwise** legally designated.

Flood Hazard Area

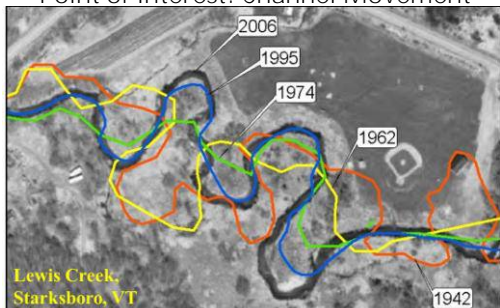
- Flood Hazard Area
 - The greater of the following two areas:
 - 1. The area within a flood plain subject to a 1-percent or greater chance of flooding in any year.
 - 2. The area designated as a flood hazard **area on a community's flood hazard map, or otherwise** legally designated.

Flood Hazard Area



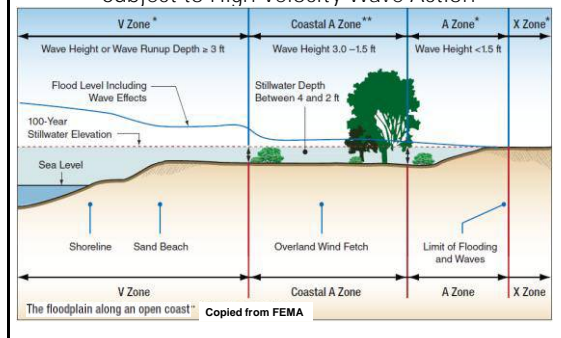
Example of Flooding

Point of Interest: Channel Movement



Special thanks to the State of Vermont for River Corridor Diagrams and Photos: Rob Evans, CFM, State Floodplain Manager, River Corridor & Floodplain Management

Flood Hazard Area Subject to High Velocity Wave Action



Substantial Damage

- Substantial Damage
Damage of any original sustained by a structure whereby the cost of restoring the structure to its before-damaged condition would be equal or exceed 50 percent of the market value of the structure before the damage occurred.



Photo By Bill Hayward



Whetstone Brook, Marlboro, VT, 2011

Substantial Improvement

Substantial Improvement

- Any repair, reconstruction, rehabilitation, addition or improvement of building or structure, the cost of which equals or exceed 50 percent of the market value of the structure before the improvement or repair is started.
- If the structure has sustained substantial damage, any repairs are considered substantial improvement regardless of the actual work performed.

Substantial Improvement

Substantial Improvement

Term does not include either:

- 1. Any project for improvement of a building required to correct existing health, sanitary or safety code violations identified by the building official and that are the minimum necessary to assure safe living conditions.
- 2. Any alterations of a historic structure provided **that the alteration will not preclude the structure's continued designation as a historic structure.**

Flood Hazard Documentation

Reference: Section 1612.5 Flood hazard documents

- Following documentation shall be prepared and sealed by a registered design professional and submitted to the Building Official
- For Construction in Flood Hazard Areas not Subject to High Velocity Wave Action
- For Construction in Flood Hazard Areas Subject to High Velocity Wave Action

Flood Hazard Documentation

Not Subject to High Velocity Wave Action:

- Elevation of lowest floor including basement
- For fully enclosed areas below design flood elevations where provisions to allow for the automatic entry and exit of flood waters do not meet the minimum requirements in section 2.6.1.1 of ASCE 24 construction documentation stating design will provide for equalization of hydrostatic flood forces in accordance with Section 2.6.1.2 ASCE 24
- For Dry Floodproofed nonresidential buildings construction documents stating dry floodproofing is designed in accordance with ASCE 24

Flood Hazard Documentation

Subject to High Velocity Wave Action:

- Elevation of the bottom of the lowest horizontal structural member
- Construction Documentation including a statement that the building is designed in accordance with ASCE 24.
 - Structure to be attached to piles, columns, foundations designed to be anchored to resist flotation, collapse and lateral movement due to the effects of wind and flood loads acting simultaneously on all building components and other load requirements of Chapter 16
- For Breakaway walls designed to a resistance of more than 20 psf, construction documents shall include a statement that the breakaway wall is designed in accordance with ASCE 24

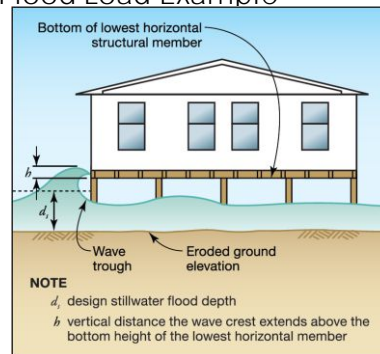
Flood Load Example:

Wave Slam - Discussion

- The action of wave crests striking the elevated portion of a structure is known as "wave slam." Wave slam introduces lateral and vertical loads on the lower portions of the elevated structure
- Wave slam force, which can be large, typically results in damaged floor systems
- This is one reason freeboard should be included in the design of coastal residential buildings.
- Lateral wave slam can be calculated using Equations, but vertical wave slam calculations are beyond the scope of this Training.

Flood Load Example

Lateral wave slam against an elevated building



Flood Loads Example:

LATERAL WAVE SLAM

$$F_s = f_s w = \frac{1}{2} \delta_w C_s d_s w$$

where:

F_s = lateral wave slam (lb)

f_s = lateral wave slam (lb/ft)

C_s = slam coefficient incorporating effects of slam duration and structure stiffness for typical residential structure (recommended value is 2.0)

δ_w = unit weight of water (62.4 lb/ft³ for fresh water and 64.0 lb/ft³ for saltwater)

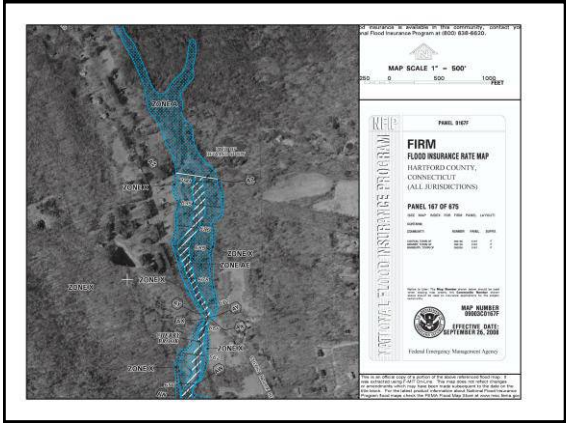
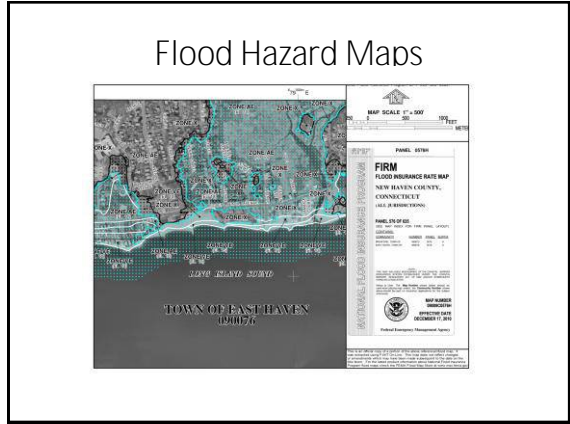
d_s = stillwater flood depth (ft)

h = vertical distance (ft) the wave crest extends above the bottom of the floor joist or floor beam

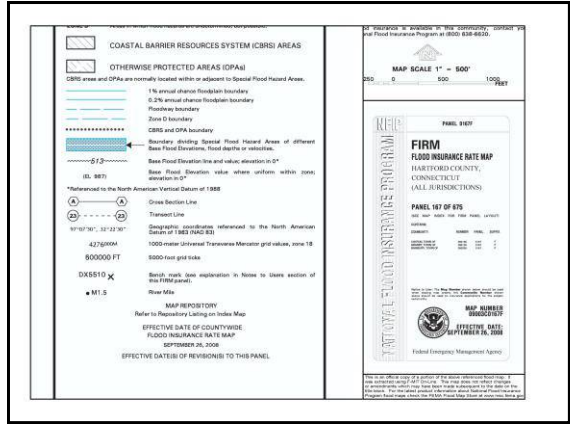
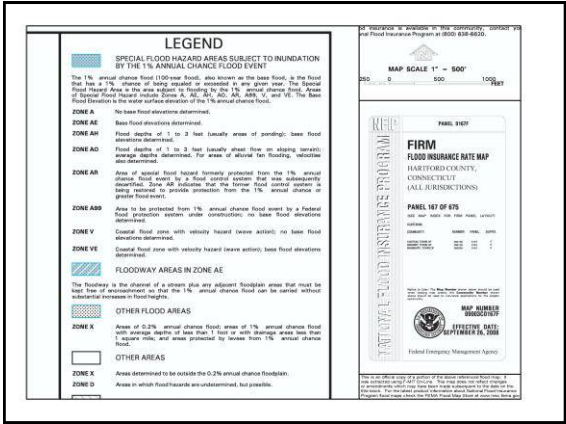
w = length (ft) of the floor joist or floor beam struck by wave crest

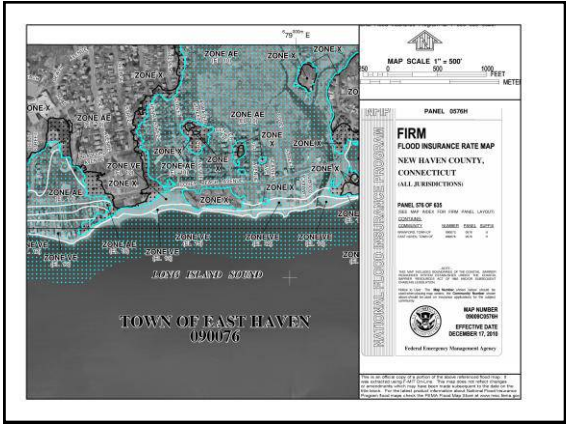


Photo By Bill Hayward



along RT 10 in Simsbury Monday afternoon after Tropical Storm Irene









Section 1803 - Excavation, Grading and Fill
 1803.4 – Grading and fill in floodways.

- Requires hydrologic and hydraulic analyses performed by a registered design professional
- In accordance with standard engineering practice
- Proposed grading or fill or both will not result in any increase in flood levels during the occurrence of the design flood.

Footings on or adjacent to slopes

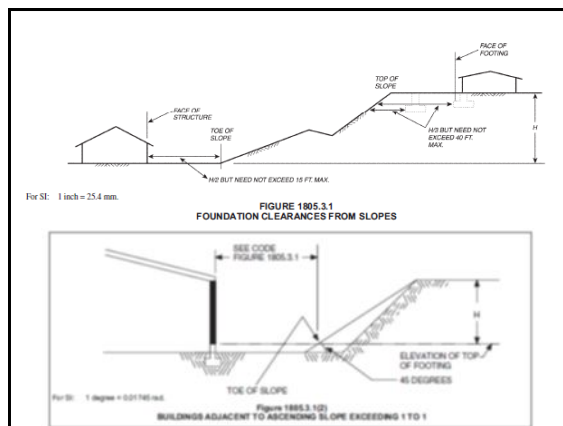
1805.3 Footings on or adjacent to slopes.

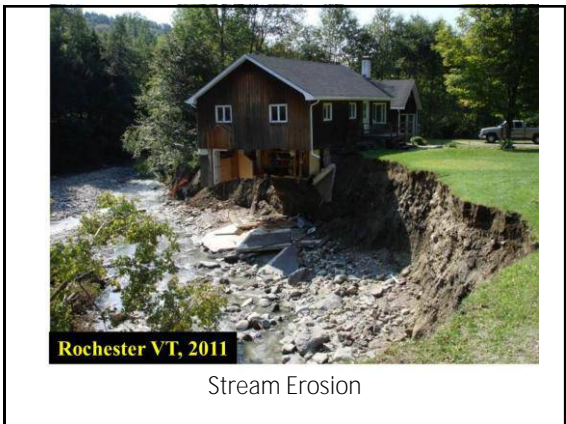
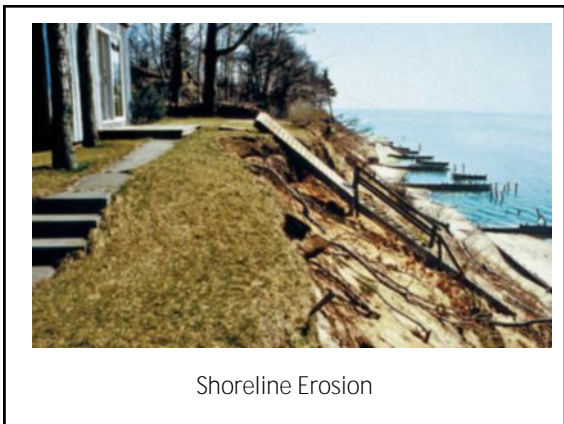
- The placement of buildings and structures on or adjacent to slopes steeper than 33.3-percent slope shall conform to:
 - 1805.3.1 Building clearance from ascending slopes
 - 1805.3.2 Footings setback from descending slope surface
 - 1805.3.4 Foundation Elevation
 - 1805.3.5 Alternate setback and clearance

Footings on or adjacent to slopes

1805.3.1 Building clearance from ascending slopes.

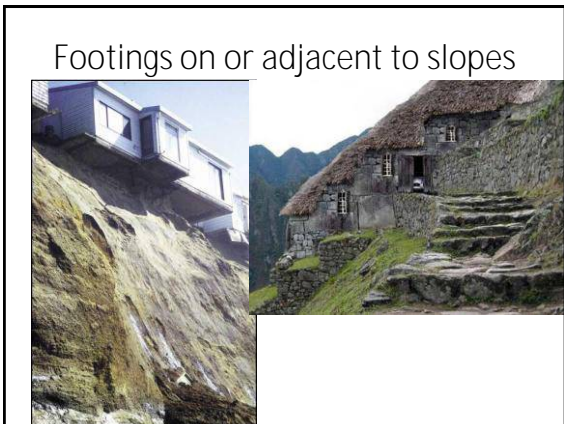
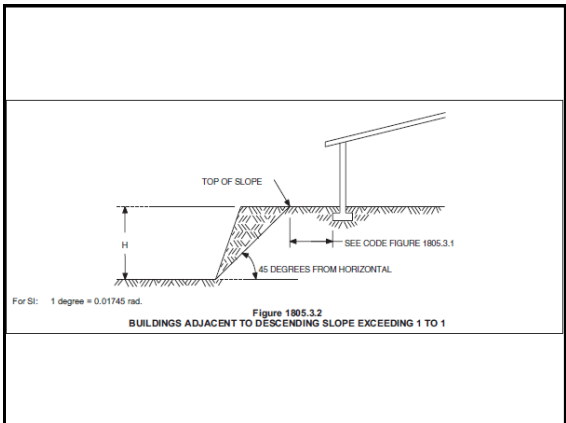
- Set a sufficient distance from the slope to provide protection from slope drainage, erosion and shallow failures.
- Where the existing slope is steeper than one unit vertical in one unit horizontal the toe of the slope shall be assumed to be at the intersection of a horizontal plane drawn from the top of the foundation and a plane drawn tangent to the slope at an angle of 45 degrees to the horizontal.
- Where a retaining wall is constructed at the toe of the slope, the height of the slope shall be measured from the top of the wall to the top of the slope.
- Except as provided for in Section 1805.3.5 and Figure 1805.3.1





Footings on or adjacent to slopes

1805.3.2 Footing setback from descending slope surface. Shall be founded in firm material with an embedment and set back from the slope surface sufficient to provide vertical and lateral support for the footing without detrimental settlement. Except as provided for in Section 1805.3.5 and Figure 1805.3.1, the following setback is deemed adequate to meet the criteria. Where the slope is steeper than 1 unit vertical in 1 unit horizontal the required setback shall be measured from an imaginary plane 45 degrees to the horizontal, projected upward from the toe of the slope.



- ### Footings on or adjacent to slopes
- 1805.3.4 Foundation elevation.
 - On graded sites, the top of any exterior foundation shall extend above the elevation of the street gutter at point of discharge or the inlet of an approved drainage device a minimum of 12 inches (305 mm) plus 2 percent.
 - Alternate elevations are permitted subject to the approval of the building official, provided it can be demonstrated that required drainage to the point of discharge and away from the structure is provided at all locations on the site.

Elevated Structure



Section 1808 Pier and Pile Foundations

- Definitions:
 - Pier Foundations
 - Pile Foundations
 - Augered uncased
 - Caisson Piles
 - Concrete-Filled Steel pipe and tube piles
 - Driven uncased piles
 - Steel-cased piles

Construction Pile Driving
See: IBC Section 1809 – Driven Pile Foundations



Section 1809

Driven Pile Foundations

1809.1 - Timber piles

- Materials
 - Round timber piles conform to ASTM D 25
 - Sawn timber piles conform to DOC PS-20
- Preservative treatment
 - Treated unless tops of piles will be below lowest ground water level for life of structure
 - Round timber – AWPA C3
 - Sawn timber – AWPA C-24
 - Pile cutoffs shall be treated - AWPA M4
- End-support piles
 - Sudden decrease in driving resistance of end supported timber pile shall be investigated.

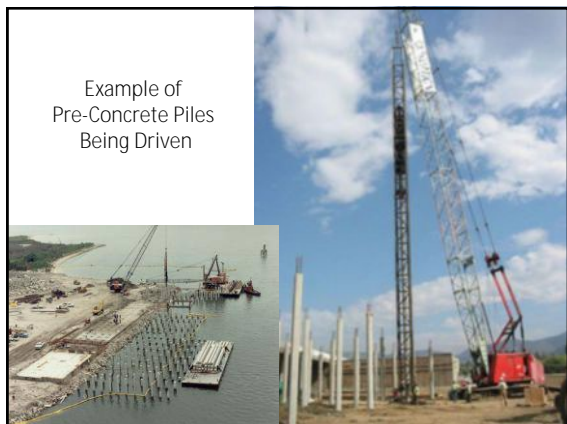
Residential Structure on Piles



Section 1809 Driven Pile Foundations

1809.2 - Precast Concrete Piles

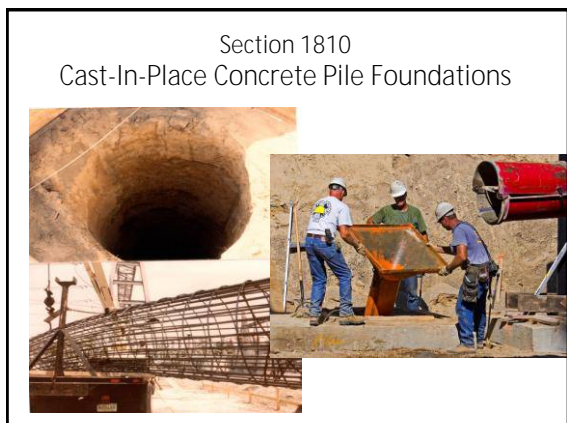
- 1809.2.1.1 Design and Manufacture
 - According to accepted engineering practice
 - To resist all stresses induce by handling, driving and service loads
- 1809.2.1.2 Minimum dimension
 - Minimum lateral dimension shall be 8 inches
 - Corners of Square piles shall be chamfered
- 1809.2.1.3 Reinforcement
- 1809.2.1.4 Installation – Piles shall be handled and driven not to cause injury or overstressing.



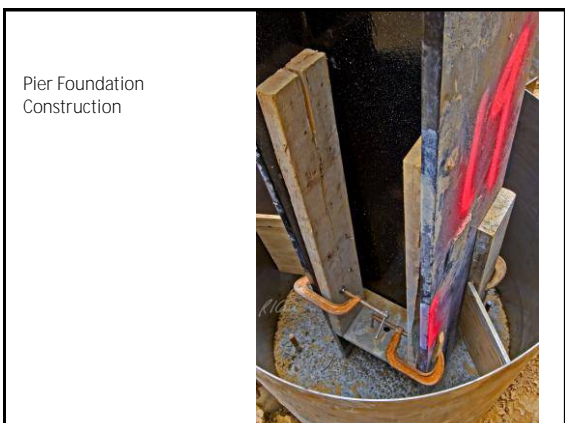
Example of Pre-Concrete Piles Being Driven

Section 1810
Cast-In-Place Concrete Pile Foundations

- 1810.1 General
- 1810.2 Enlarged bas piles
- 1810.3 Drilled or augered uncased piles
- 1810.4 Driven uncased piles
- 1810.5 Steel-cased piles
- 1810.6 Concrete-filled steel pipe and tubes piles.
- 1810.6 Caisson piles



Section 1810
Cast-In-Place Concrete Pile Foundations



Pier Foundation Construction

Section 1811
Composite Piles

- 1811.1 General.
 - Composite piles shall conform to the requirements of Sections 1811.2 through 1811.5.
- 1811.2 Design.
 - Composite piles consisting of two or more approved pile types shall be designed to meet the conditions of installation
- 1811.3 Limitation of load.
 - The maximum allowable load shall be limited by the capacity of the weakest section incorporated in the pile.
- 1811.4 Splices.
 - Splices between concrete and steel or wood designed to prevent separation, ensure the alignment and transmission of the total pile load.
- 1811.5 Seismic reinforcement.

Section 1812
Pier Foundations

- Section 1812 addresses general requirements for the construction of isolated pier foundations (drilled or excavated shafts with or without belled bottoms) using plain or reinforced concrete or piers encased by steel shafts.

ICC and FEMA Documents

A compilation of flood resistant provisions, prepared by FEMA for the following ICC Codes:

- International Residential Code: 2009 and 2012
- International Building Code: 2009 and 2012
- International Existing Building Code: 2009 and 2012
- International Mechanical Code: 2009 and 2012
- International Plumbing Code: 2009 and 2012

- Copyright 2009, Falls Church, Virginia: International Code Council, Inc. Reproduced with permission. All rights reserved.
- 2012 reproduces excerpts, International Code Council, Inc., Washington, D.C. Reproduced with permission. All rights reserved.

Residential



International Residential Code R102.7 Existing structures.

- R102.7.1 Additions, alterations or repairs. Additions, alterations or repairs to any structure shall conform to the requirements for a new structure without requiring the existing structure to comply with all of the requirements of this code, unless otherwise stated. Additions, alterations or repairs shall not cause an existing structure to become unsafe or adversely affect the performance of the building.

R104.10 Modifications.

- R104.10.1 Areas prone to flooding. The building official shall not grant modifications to any provision related to areas prone to flooding as established by Table R301.2(1) without the granting of a variance to such provisions by the board of appeals.

Substantial Improvement or Substantial Damage

R105.3.1.1 Substantially improved or substantially damaged existing buildings in flood hazard areas.

- For applications for reconstruction, rehabilitation, addition or other improvement of existing buildings or structures located in an area prone to flooding as established by Table R301.2(1), the building official shall examine or cause to be examined the construction documents and shall prepare a finding with regard to the value of the proposed work.

Substantial Improvement or Substantial Damage

R105.3.1.1 - Substantially improved or substantially damaged existing buildings in flood hazard areas.

- If the building official finds that the value of proposed work equals or exceeds 50 percent of the market value of the building or structure before the damage has occurred or the improvement is started, the finding shall be provided to the board of appeals for a determination of substantial improvement or substantial damage.
- Applications determined by the board of appeals to constitute substantial improvement or substantial damage shall require all existing portions of the entire building or structure to meet the requirements of R322.

R106.1.3 Information for construction in flood hazard areas.

1. Delineation of flood hazard areas, floodway boundaries and flood zones and the design flood elevation, as appropriate;
2. The elevation of the proposed lowest floor, including basement; in areas of shallow flooding (AO zones), the height of the proposed lowest floor, including basement, above the highest adjacent finished grade; and
3. The elevation of the bottom of the lowest horizontal structural member in coastal high-hazard areas (V Zone); and
4. **If design flood elevations are not included on the community's Flood Insurance Rate Map (FIRM), the building official and the applicant shall obtain and reasonably utilize any design flood elevation and floodway data available from other sources.**

Floodplain inspections

R109.1.3 Floodplain inspections.

- For construction in areas prone to flooding as established by Table 301.2(1), upon placement of the lowest floor, including basement, and prior to further vertical construction, the building official shall require submission of documentation, prepared and sealed by a registered design professional, of the elevation of the lowest floor, including basement, required in Section R322.

Floodplain construction

R301.2.4 Floodplain construction.

Buildings and structures constructed in whole or in part in flood hazard areas (including A or V Zones) as established in Table R301.2(1) shall be designed and constructed in accordance with Section R322. Buildings and structures located in whole or in part in identified floodways shall be designed and constructed in accordance with ASCE 24.

Alternative provisions

R301.2.4.1 Alternative provisions.

- As an alternative to the requirements in Section R322.3 for buildings and structures located in whole or in part in coastal high-hazard areas (V Zones) and coastal A Zones, if delineated, ASCE 24 is permitted subject to the limitations of this code and the limitations therein.

Garages and Carports

R309.3 [Garages and Carports] Flood hazard areas.

For buildings located in flood hazard areas as established by Table 301.2(1), garage floors shall be:

1. Elevated to or above the design flood elevation as determined in Section R322; or
2. Located below the design flood elevation provided they are at or above grade on at least one side, are used solely for parking, building access, or storage, meet the requirements of Section R322 and are otherwise constructed in accordance with this code.

IRC SECTION R322 FLOOD-RESISTANT CONSTRUCTION

FLOOD-RESISTANT CONSTRUCTION in the 2012 versus 2009 IRC

- **"Flood Hazard Areas" replaced "Areas Prone to Flooding"**

IRC SECTION R322

- Was amended for the 2012 by moving exceptions into body of the provisions
- Allowing the use of ASCE within Coastal A zones if delineated.
- Section R322.3.2 Deleted reference to mat and raft foundations that support columns which if permitted must be design in accordance to ASCE 24.
- Section R322.3.3 Added requirement that the space below elevated homes must be free of obstructions, or if enclosed by walls, the walls must meet the requirements of R322.3.4

**IRC SECTION R322
FLOOD-RESISTANT CONSTRUCTION**

- R322.1 General. Buildings and structures constructed in whole or in part in flood hazard areas (including A or V Zones) as established in Table R301.2(1) shall be designed and constructed in accordance with the provisions contained in this section. Buildings and structures located in whole or in part in identified floodways shall be designed and constructed in accordance with ASCE 24.

Alternative

R322.1.1 Alternative provisions.

- As an alternative to the requirements in Section R322.3 for buildings and structures located in whole or in part in coastal high-hazard areas (V Zones) and coastal A Zones, if delineated, ASCE 24 is permitted subject to the limitations of this code and the limitations therein.

Flood-Resistant Construction

- R322.1.2 Structural systems. All structural systems of all buildings and structures shall be designed, connected and anchored to resist flotation, collapse or permanent lateral movement due to structural loads and stresses from flooding equal to the design flood elevation.
- R322.1.3 Flood-resistant construction. All buildings and structures erected in flood hazard areas shall be constructed by methods and practices that minimize flood damage.



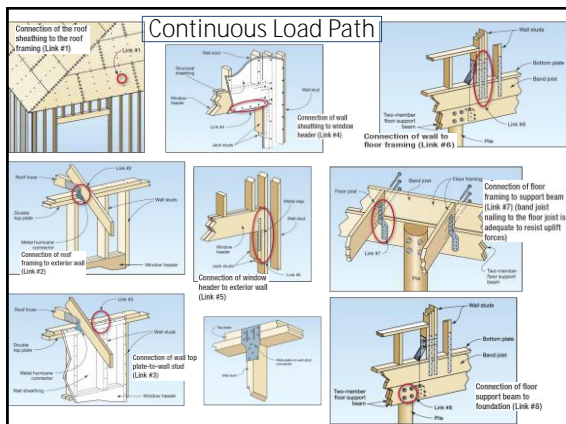
Shear wall hold down connector with bracket attached to a wood beam



(Bettina Hansen, Hartford Courant / August 29, 2011)
Photo taken after [Hurricane Irene](#), Coesey Beach in East Haven. This home was swept right off its pilings.



Metals corrode at a much faster rate near the ocean. Always use well-protected hardware, such as this connector with thick galvanizing.



Design Flood Elevation

R322.1.4 Establishing the design flood elevation.

- The design flood elevation shall be used to define areas prone to flooding. At a minimum, the design flood elevation is the higher of:
 - The base flood elevation at the depth of peak elevation of flooding (including wave height) which has a 1 percent (100-year flood) or greater chance of being equaled or exceeded in any given year; or
 - The elevation of the design flood associated with the area designated on a flood hazard map adopted by the community, or otherwise legally designated.

Determination of Design Flood Elevations

R322.1.4.1 Determination of design flood elevations.

If design flood elevations are not specified, the building official is authorized to require the applicant to:

- Obtain and reasonably utilize data available from a federal, state or other source; or
- Determine the design flood elevation in accordance with accepted hydrologic and hydraulic engineering practices used to define special flood hazard areas. Determinations shall be undertaken by a registered design professional who shall document that the technical methods used reflect currently accepted engineering practice. Studies, analyses and computations shall be submitted in sufficient detail to allow thorough review and approval.

Determination of impacts

R322.1.4.2 Determination of impacts.

In riverine flood hazard areas where design flood elevations are specified but floodways have not been designated, the applicant shall demonstrate that the effect of the proposed buildings and structures on design flood elevations, including fill, when combined with all other existing and anticipated flood hazard area encroachments, will not increase the design flood elevation more than one foot (305 mm) at any point within the jurisdiction.

Lowest floor

- R322.1.5 Lowest floor. The lowest floor shall be the floor of the lowest enclosed area, including basement, but excluding any unfinished flood-resistant enclosure that is useable solely for vehicle parking, building access or limited storage provided that such enclosure is not built so as to render the building or structure in violation of this section.

Protection of mechanical and electrical systems.

R322.1.6 Protection of mechanical and electrical systems.

Electrical systems, equipment and components; heating, ventilating, air conditioning; plumbing appliances and plumbing fixtures; duct systems; and other service equipment shall be located at or above the elevation required in Section R322.2 (flood hazard areas including A Zones) or R322.3 (coastal high-hazard areas including V Zones).

If replaced as part of a substantial improvement, electrical systems, equipment and components; heating, ventilation, air conditioning and plumbing appliances and plumbing fixtures; duct systems; and other service equipment shall meet the requirements of this section. Systems, fixtures, and equipment and components shall not be mounted on or penetrate through walls intended to break away under flood loads.

Protection of mechanical and electrical systems.

R322.1.6 Exception:

- Locating electrical systems, equipment and components: heating, ventilating, air conditioning, plumbing appliances and plumbing fixtures; duct systems; and other service equipment is permitted below the elevation required in Section R322.2 (flood hazard areas including A Zones) or R322.3 (coastal high-hazard areas including V Zones) provided that
 - they are designed and installed to prevent water from entering or accumulating within the components and to resist hydrostatic and hydrodynamic loads and stresses, including the effects of buoyancy, during the occurrence of flooding to the design flood elevation in accordance with ASCE 24.
 - Electrical wiring systems are permitted to be located below the required elevation provided they conform to the provisions of the electrical part of this code for wet locations.

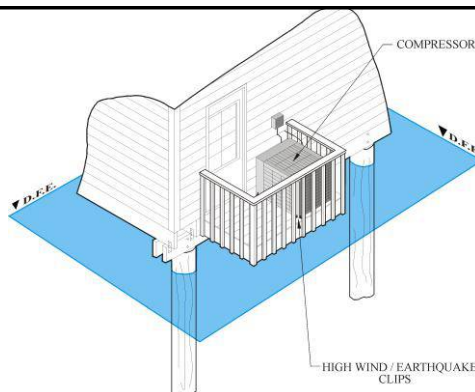
Elevation of Equipment

- According to FEMA: The most effective flood protection technique is to locate the furnace or boiler on a floor that is elevated above the DFE.
- Elevation can also be achieved by using a lateral or in-line furnace that fits into the ductwork at any location above the DFE.

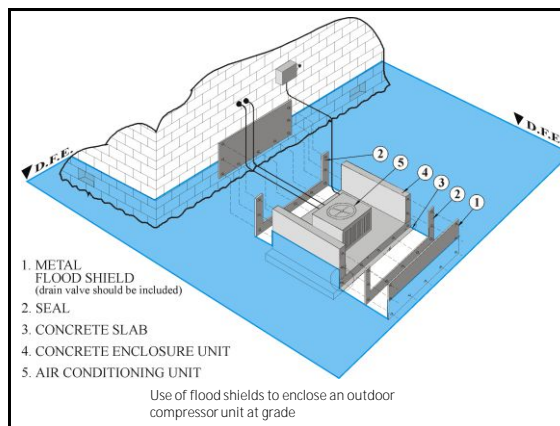
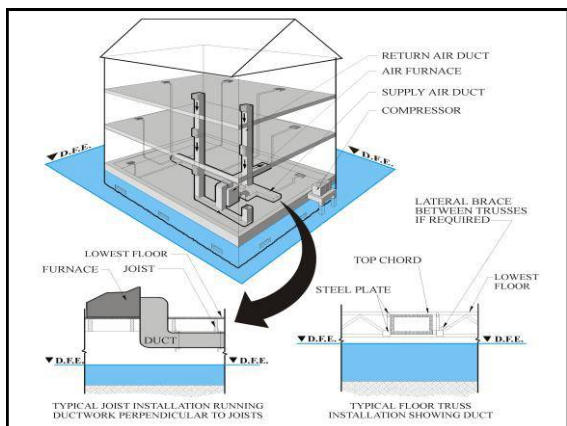
Such furnace units usually include a blower. For cooling, an evaporator coil can be added to the same unit.



Electric heat pump dislocated from its shattered wooden stand by velocity flow in a coastal area

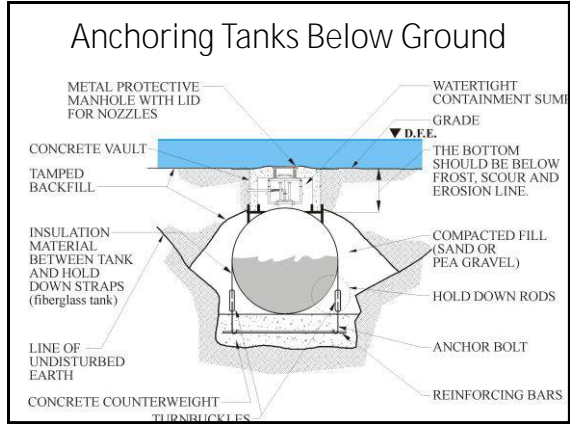
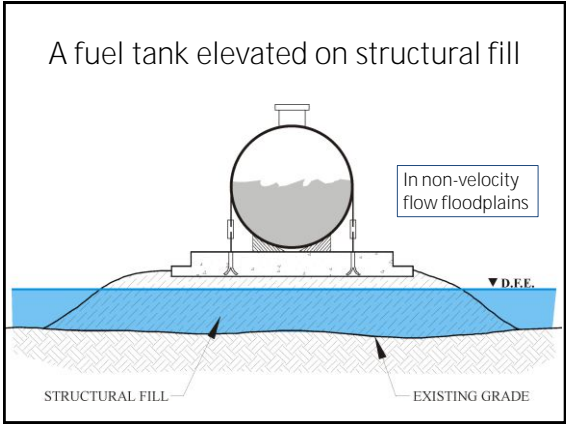
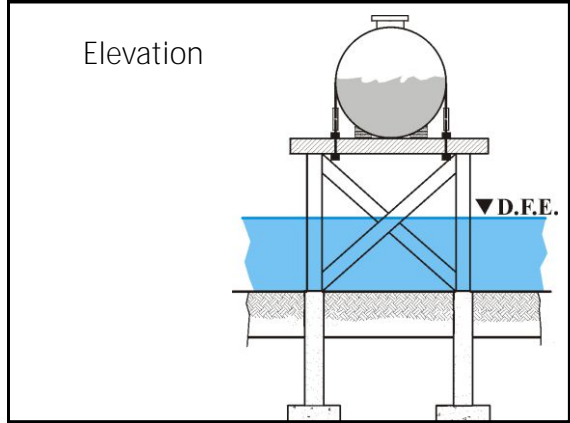
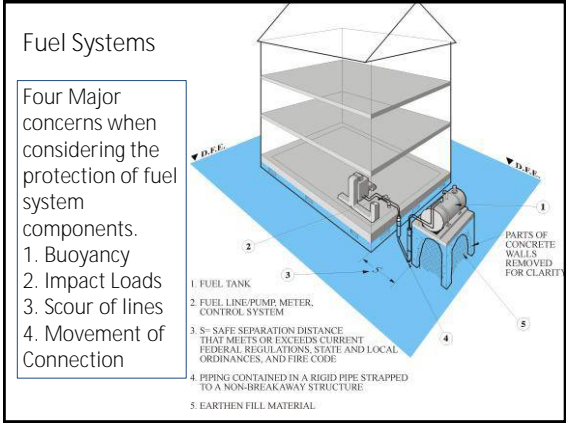
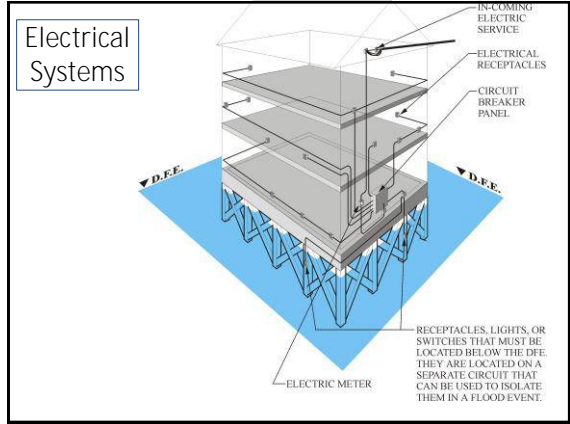
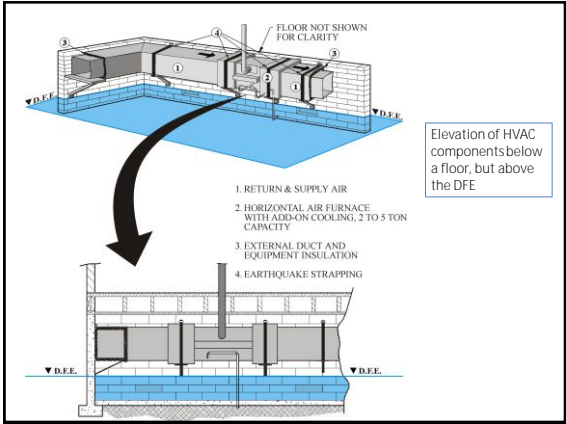


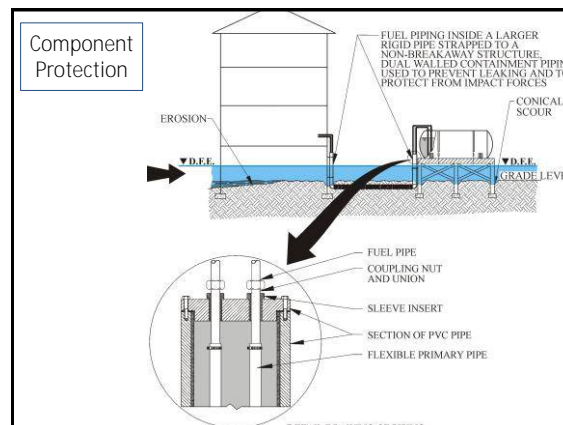
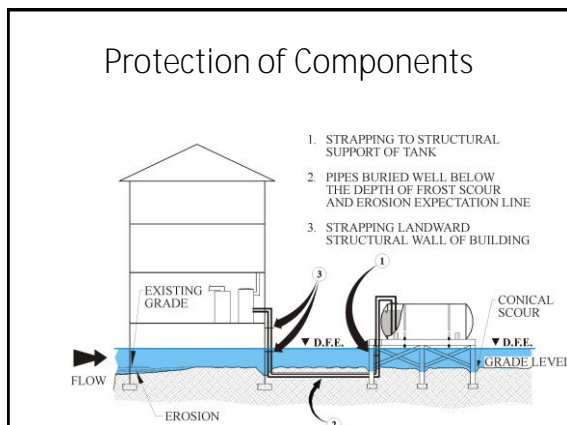
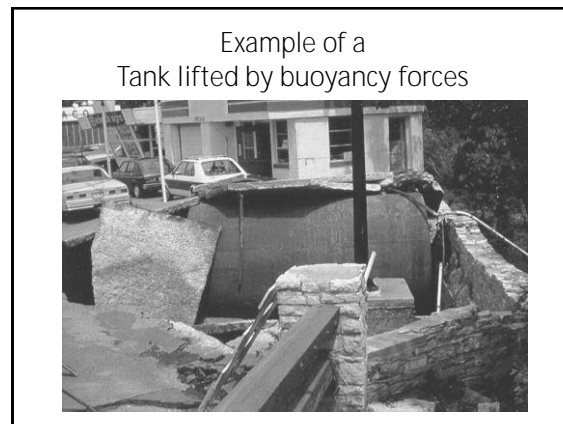
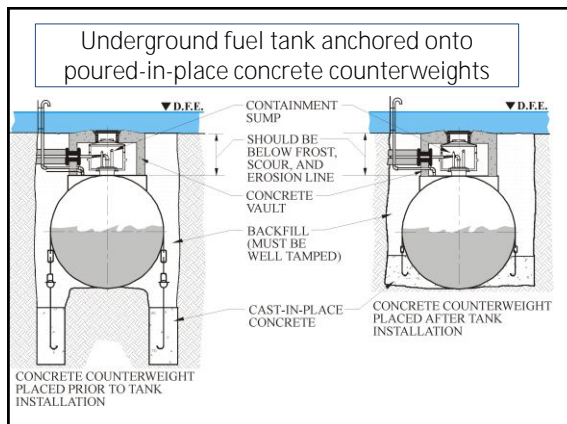
A cantilevered compressor platform beside a house in a velocity flow area



- METAL FLOOD SHIELD (drain valve should be included)
- SEAL
- CONCRETE SLAB
- CONCRETE ENCLOSURE UNIT
- AIR CONDITIONING UNIT

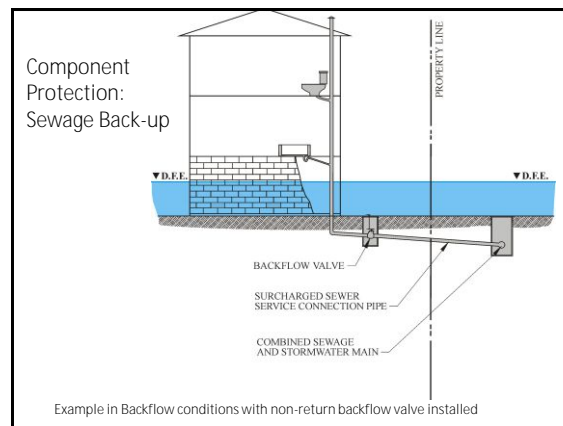
Use of flood shields to enclose an outdoor compressor unit at grade

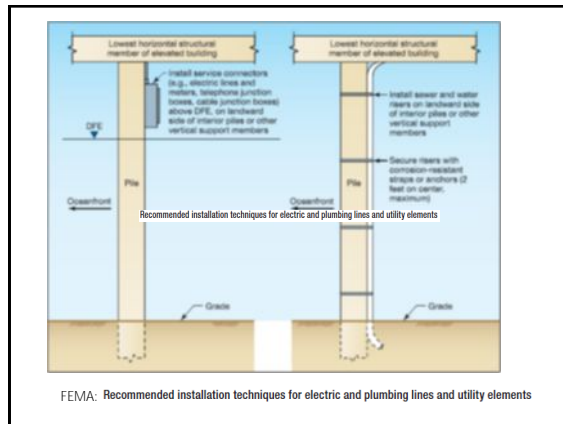
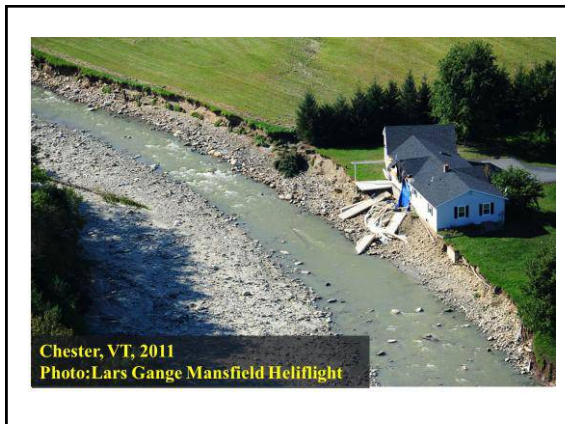




Protection of water supply and sanitary sewage systems

R322.1.7 Protection of water supply and sanitary sewage systems. New and replacement water supply systems shall be designed to minimize or eliminate infiltration of flood waters into the systems in accordance with the plumbing provisions of this code. New and replacement sanitary sewage systems shall be designed to minimize or eliminate infiltration of floodwaters into systems and discharges from systems into floodwaters in accordance with the plumbing provisions of this code and Chapter 3 of the *International Private Sewage Disposal Code*.





Flood-resistant materials

R322.1.8 Flood-resistant materials. Building materials used below the elevation required in Section R322.2 (flood hazard areas including A Zones) or R322.3 (coastal high-hazard areas including V Zones) shall comply with the following:

1. All wood, including floor sheathing, shall be pressure-preservative-treated in accordance with AWPA U1 for the species, product, preservative and end use or be the decay-resistant heartwood of redwood, black locust or cedars. Preservatives shall be listed in Section 4 of AWPA U1.
2. Materials and installation methods used for flooring and interior and exterior walls and wall coverings shall conform to the provisions of FEMA/FIA-TB-2.

Enclosed Area Below Design Flood Elevation.

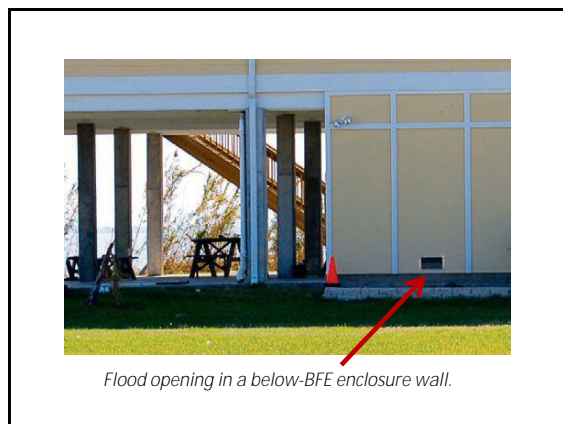
R322.2.2 Enclosed area below design flood elevation. Enclosed areas, including crawl spaces, that are below the design flood elevation shall:

1. Be used solely for parking of vehicles, building access or storage.
2. Be provided with flood openings that meet the following criteria:
 - 2.1. There shall be a minimum of two openings on different sides of each enclosed area; if a building has more than one enclosed area below the design flood elevation, each area shall have openings on exterior walls.

- See Next Slide for 2.2 through 2.6:

Flood Openings Criteria

- 2.2. The total net area of all openings shall be at least 1 square inch (645 mm²) for each square foot (0.093 m²) of enclosed area, or the openings shall be designed and the construction documents shall include a statement by a registered design professional that the design of the openings will provide for equalization of hydrostatic flood forces on exterior walls by allowing for the automatic entry and exit of floodwaters as specified in Section 2.6.2.2 of ASCE 24.
- 2.3. The bottom of each opening shall be 1 foot (305 mm) or less above the adjacent ground level.
- 2.4. Openings shall be not less than 3 inches (76 mm) in any direction in the plane of the wall.
- 2.5. Any louvers, screens or other opening covers shall allow the automatic flow of floodwaters into and out of the enclosed area.
- 2.6. Openings installed in doors and windows, that meet requirements 2.1 through 2.5, are acceptable; however, doors and windows without installed openings do not meet the requirements of this section.



Foundation Design and Construction.

R322.2.3 Foundation design and construction.
 Foundation walls for all buildings and structures erected in flood hazard areas shall meet the requirements of Chapter 4.
 Exception: Unless designed in accordance with Section 404:
 1. The unsupported height of 6-inch (152 mm) plain masonry walls shall be no more than 3 feet (914 mm).
 2. The unsupported height of 8-inch (203 mm) plain masonry walls shall be no more than 4 feet (1219 mm).
 3. The unsupported height of 8-inch (203 mm) reinforced masonry walls shall be no more than 8 feet (2438 mm).
 For the purpose of this exception, unsupported height is the distance from the finished grade of the under-floor space to the top of the wall.

Coastal high-hazard areas

R322.3 Coastal high-hazard areas (including V Zones). Areas that have been determined to be subject to wave heights in excess of 3 feet (914 mm) or subject to high-velocity wave action or wave-induced erosion shall be designated as coastal high-hazard areas. All buildings and structures constructed in whole or in part in coastal high-hazard areas shall be designed and constructed in accordance with Sections R322.3.1 through R322.3.6.

Location and site preparation

R322.3.1 Location and site preparation.
 1. New buildings and buildings that are determined to be substantially improved pursuant to Section R105.3.1.1 shall be located landward of the reach of mean high tide.
 2. For any alteration of sand dunes and mangrove stands the building official shall require submission of an engineering analysis which demonstrates that the proposed alteration will not increase the potential for flood damage.

Elevation requirements.

R322.3.2 Elevation requirements.
 1. All buildings and structures erected within coastal high-hazard areas shall be elevated so that the lowest portion of all structural members supporting the lowest floor, with the exception of piling, pile caps, columns, grade beams and bracing, is:
 1.1 Located at or above the design flood elevation, if the lowest horizontal structural member is oriented parallel to the direction of wave approach, where parallel shall mean less than or equal to 20 degrees (0.35 rad) from the direction of approach, or
 1.2 Located at the base flood elevation plus 1 foot (305 mm), or the design flood elevation, whichever is higher, if the lowest horizontal structural member is oriented perpendicular to the direction of wave approach, where perpendicular shall mean greater than 20 degrees (0.35 rad) from the direction of approach.

Elevation requirements.

R322.3.2 Elevation requirements.
 2. Basement floors that are below grade on all sides are prohibited.
 3. The use of fill for structural support is prohibited.
 4. Minor grading, and the placement of minor quantities of fill, shall be permitted for landscaping and for drainage purposes under and around buildings and for support of parking slabs, pool decks, patios and walkways.
 Exception: Walls and partitions enclosing areas below the design flood elevation shall meet the requirements of Sections R322.3.4 and R322.3.5.

Foundations.

R322.3.3 Foundations.
 All buildings and structures erected in coastal high-hazard areas shall be supported on pilings or columns and shall be adequately anchored to such pilings or columns.
 • Pilings shall have adequate soil penetrations to resist the combined wave and wind loads (lateral and uplift). Water loading values used shall be those associated with the design flood. Wind loading values shall be those required by this code.
 • Pile embedment shall include consideration of decreased resistance capacity caused by scour of soil strata surrounding the piling.
 • Pile systems design and installation shall be certified in accordance with Section R322.3.6.

Foundations.

R322.3.3 Foundations. continued

- Spread footings, mat, raft or other foundations that support columns shall not be permitted where soil investigations that are required in accordance with Section R401.4 indicate that soil material under the spread footing, mat, raft or other foundation is subject to scour or erosion from wave-velocity flow conditions.
- If permitted spread footing, mat, raft or other foundation must be design in accordance to ASCE 24.
- Slabs, pools, pool decks and walkways shall be located and constructed to be structurally independent of buildings and structures and their foundations to prevent transfer of flood loads to the buildings and structures during conditions of flooding, scour or erosion from wave-velocity flow conditions, unless the buildings and structures and their foundation are designed to resist the additional flood load.



These footings appeared to have been subjected to scour or erosion from wave action



Deck Construction

Walls below design flood elevation.

R322.3.4 Walls below design flood elevation. Walls and partitions are permitted below the elevated floor, provided that such walls and partitions are not part of the structural support of the building or structure and:

1. Electrical, mechanical, and plumbing system components are not to be mounted on or penetrate through walls that are designed to break away under flood loads; and
2. Are constructed with insect screening or open lattice; or

Walls below design flood elevation.

R322.3.4 Walls below design flood elevation.

3. Are designed to break away or collapse without causing collapse, displacement or other structural damage to the elevated portion of the building or supporting foundation system. Such walls, framing and connections shall have a design safe loading resistance of not less than 10 (470 Pa) and no more than 20 pounds per square foot (958 Pa); or



Building siding extended down and over the breakaway wall. Lack of a clean separation allowed damage to spread upward as the breakaway wall failed.

Walls below design flood elevation.

R322.3.4 Walls below design flood elevation.

- 4. Where wind loading values of this code exceed 20 pounds per square foot (958 Pa), the construction documents shall include documentation prepared and sealed by a registered design professional that:
 - 4.1. The walls and partitions below the design flood elevation have been designed to collapse from a water load less than that which would occur during the design flood.
 - 4.2. The elevated portion of the building and supporting foundation system have been designed to withstand the effects of wind and flood loads acting simultaneously on all building components (structural and nonstructural). Water loading values used shall be those associated with the design flood. Wind loading values used shall be those required by this code.

Enclosed areas below design flood elevation.

R322.3.5 Enclosed areas below design flood elevation.

Enclosed areas below the design flood elevation shall be used solely for parking of vehicles, building access or storage.



Construction Documents

- R322.3.6 Construction documents.
The construction documents shall include documentation that is prepared and sealed by a registered design professional that the design and methods of construction to be used meet the applicable criteria of this section.

Foundation Drainage

- R401.3 [Foundations] Drainage.
Surface drainage shall be diverted to a storm sewer conveyance or other approved point of collection so as to not create a hazard. Lots shall be graded so as to drain surface water away from foundation walls. . . .

IRC Section R404 Foundation and Retaining Walls

Section R404.1.9.5 - Masonry piers in flood hazard areas.

- Masonry piers for dwellings in the flood hazard areas shall be designed in accordance with Section R322.

Under Floor Space

R408.6 [Under-Floor Space] Finished grade. The finished grade of under-floor surface may be located at the bottom of the footings; however, where there is evidence that the groundwater table can rise to within 6 inches (152 mm) of the finished floor at the building perimeter or where there is evidence that the surface water does not readily drain from the building site, the grade in the under-floor space shall be as high as the outside finished grade, unless an approved drainage system is provided.

R408.7 [Under-Floor Space] Flood resistance. For buildings located in flood hazard areas as established in Table R301.2(1):

1. Walls enclosing the under-floor space shall be provided with flood openings in accordance with Section R322.2.2.
2. The finished ground level of the under-floor space shall be equal to or higher than the outside finished ground level on at least one side.

Exception: Under-floor spaces that meet the requirements of FEMA/FIA TB 11-01.

R408.7 Flood resistance

1. Walls enclosing the under-floor space shall be provided with flood openings in accordance with Section R322.2.2.



A house where flood openings have been covered by insulation and drywall

Mechanical Systems

- M1301.1.1 [General Mechanical System Requirements] Flood-resistant installation. In flood hazard areas as established by Table R301.2(1), mechanical appliances, equipment and systems shall be located or installed in accordance with Section R322.1.6
- M1401.5 [Heating and Cooling Equipment] Flood hazard. In flood hazard areas as established by Table R301.2(1), heating and cooling equipment and appliances shall be located or installed in accordance with Section R322.1.6
- M1601.4.9 [Duct Construction] Flood hazard areas. In flood hazard areas as established by Table R301.2(1), duct systems shall be located or installed in accordance with Section R322.1.6.

Mechanical Systems

- M1701.2 [Combustion air] Opening location. In flood hazard areas as established by Table R301.2(1), openings shall be located at or above the elevation required in Section R322.2.1 or R322.3.2.
- M2001.4 [Boilers and Water Heaters] Flood-resistant installation. In flood hazard areas as established in Table R301.2(1), boilers, water heaters and their control systems shall be located or installed in accordance with Section R322.1.6.
- M2201.6 [Special Piping and Storage Systems] Flood resistant installation. In flood hazard areas as established by Table R301.2(1), tanks shall be installed at or above the elevation required in Section R322.2.1 or R322.3.2 or shall be anchored to prevent flotation, collapse and lateral movement under conditions of the design flood.

Fuel Gas

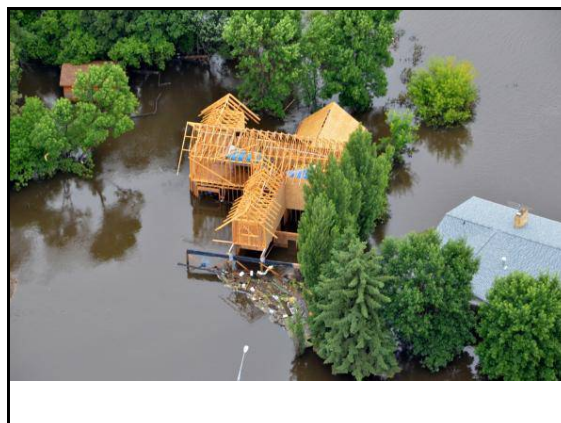
G2404.7 (301.11) [Fuel Gas] Flood hazard.

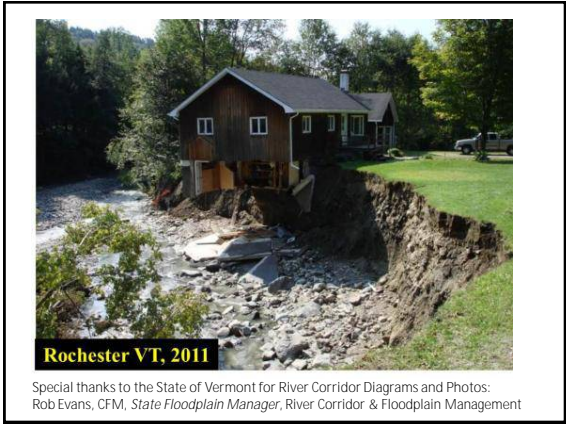
For structures located in flood hazard areas, the appliance, equipment and system installations regulated by this code shall be located at or above the design flood elevation and shall comply with the flood-resistant construction requirement of Section R322.

- Exception: The appliance, equipment and system installations regulated by this code are permitted to be located below the design flood elevation provided that they are designed and installed to prevent water from entering or accumulating within the components and to resist hydrostatic and hydrodynamic loads and stresses, including the effects of buoyancy, during the occurrence of flooding to the design flood elevation and shall comply with the flood-resistant construction requirements of Section R322.

Plumbing Systems

- P2705.1 [Plumbing Fixtures, Installation] General. 7. In flood hazard areas as established by Table R301.2(1), plumbing fixtures shall be located or installed in accordance with Section R322.1.6.
- P3001.3 [Sanitary Drainage] Flood-resistant installation. In flood hazard areas as established by Table R301.2(1), drainage, waste and vent systems shall be located and installed to prevent infiltration of floodwaters into the systems and discharges from the systems into floodwaters.
- P3101.5 [Vent Systems] Flood resistance. In flood hazard areas as established by Table R301.2(1), vents shall be located at or above the elevation required in Section R322.2.1 (flood hazard areas including A Zones) or R322.3.2 (coastal high-hazard areas including V Zones).





References

- 2012 International Building Code
- 2009 and 2012 International Residential Code
- A compilation of flood resistant provisions from the ICC Model Codes, prepared by FEMA Copyright 2009, Falls Church, Virginia: International Code Council, Inc. Reproduced with permission. All rights reserved.
- 2005 Connecticut State Building Code
 - 2005 Connecticut Supplement
 - 2013 and 2011 Amendments to the 2005 State Building Code
 - 2009 International Residential Code
 - 2003 International Building Code
- Coastal Construction Manual,
 - FEMA P-55, August 2011 Volume I and II
- Other Related FEMA and ASCE Documents



Thank-You!

State of Connecticut
Department of Construction Services

- Office of the State Building Inspector
– (860) 713 - 5900
- Office of the State Fire Marshal
– (860) 713 - 5750
- Office of Education and Data Management
– (860) 713- 5522

Office of Education and Data Management 160